

# HEGLA – Vacuum Lifting Device

Hubfix F-G 1 - Capacity 220 kg

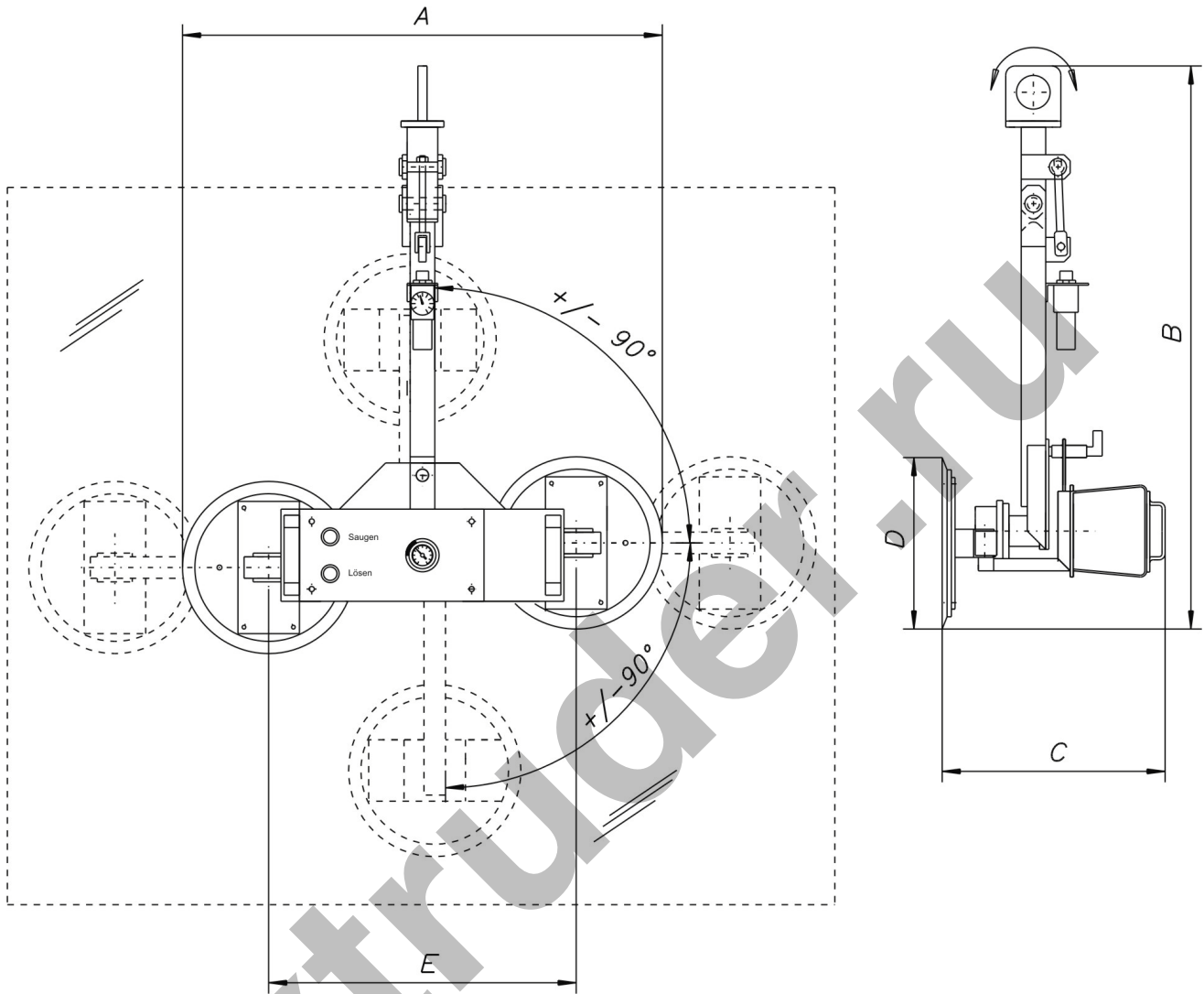

The Hubfix F-G 1 is equipped with a manual turning feature of 0° and 90°.			
This vacuum lifting device is optional available with a vacuum pump for 230/400 V.			
<b>(A) Width</b>	780 – 1280 mm	<b>Vacuum production</b>	Ejector + Safety valve
<b>(B) Height</b>	1000 mm	<b>Operating pressure</b>	6 to 8 bar
<b>(C) Depth</b>	370 mm	<b>Air Consumption</b>	3,6 Nm <sup>3</sup> /h
<b>(D) Suction cup diameter</b>	280 mm	<b>Connection with quick-release coupling</b>	NW 13
<b>(E) Suction cup distance</b>	500 – 1000 mm		
<b>Number of suction cups</b>	2 pieces		
<b>Weight</b>	30 kg		

The products shown partly contain supplementary equipment being sold for additional charge. Obliging is only our written offer and the information of your HEGLA consultant. Copyright © 2001 HEGLA, Beverungen. All rights reserved. Duplicating, also in extracts, only with written permission of HEGLA.

## HEGLA

Industriestraße 21  
D-37688 Beverungen  
Phone: +49 (0) 52 73 / 9 05-0  
Fax: +49 (0) 52 73 / 9 05-2 55  
Email: info@hegla.de

## HEGLA

Industriering 5  
D-06712 Döschwitz  
Phone: +49 (0) 3 44 25 / 5 01-0  
Fax: +49 (0) 3 44 25 / 5 01-29  
Email: info@hegla.de

## HEGLA

Industriestraße 27  
D-74589 Satteldorf  
Phone: +49 (0) 79 51 / 94 35-0  
Fax: +49 (0) 79 51 / 94 35-50  
Email: info@hegla.de

## HEGLA France

4, rue d'Otterswiller  
F-67700 Saverne  
Phone: +33 3 88 / 91 01 01  
Fax: +33 3 88 / 91 05 05  
Email: hegla.france@wanadoo.fr

## HEGLA Corp.

1626-G Virginia Ave  
College Park, GA 30337  
Phone: +1 404 763 97 00  
Fax: +1 404 763 09 01  
Email: info@heglacorp.com

## HEGLA Machinery (UK) Ltd.

Milton Keynes  
GB-Buckinghamshire, MK8 0AJ  
Phone: +44 19 08 / 26 19 33  
Fax: +44 19 08 / 26 19 50  
Email: steven.goble@hegla.co.uk